

GN 923.18



GN 923.30



Disc handwheel Ø 80

for linear actuators Ø 18

SPECIFICATION

Type

- Type **R**: with revolving handle

Bore code

- Version **K**: with keyway

Aluminium die casting

Hub machined

Rim turned

plastic coated

black, RAL 9005, textured finish **SW**

Concentric runout and axial runout deviation of the rim < 0.4

Revolving handles GN 798.2 (see page 578)

Plastic, Technopolymer

black, matt

INFORMATION

- Linear actuators GN 291 (see page 1912)

Disc handwheel Ø 100

for linear actuators Ø 30

SPECIFICATION

Type

- Type **R**: with revolving handle

Bore code

- Version **K**: with keyway

Aluminium die casting

Hub machined

Rim turned

plastic coated

black, RAL 9005, textured finish **SW**

Concentric runout and axial runout deviation of the rim < 0.4

Revolving handles GN 798.2 (see page 578)

Plastic, Technopolymer

black, matt

INFORMATION

- Linear actuators GN 291 (see page 1912)

- Linear actuators GN 291.1 (see page 1930)

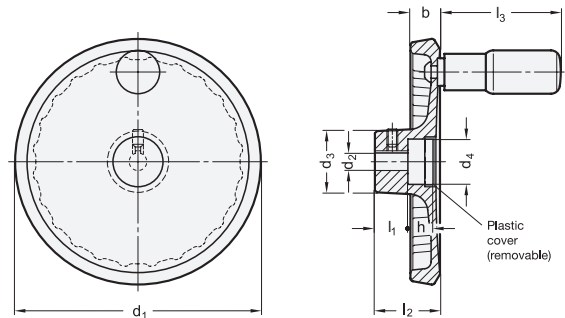
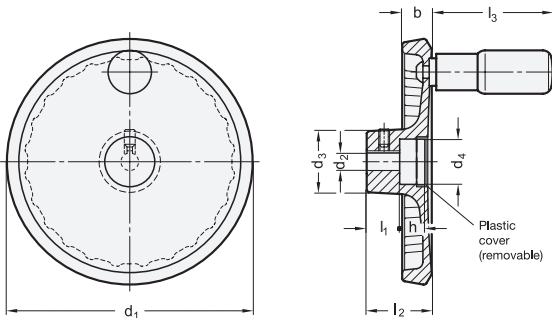

GN 923.18

Description	d1	d2	d3	d4	b	h	l1	l2	l3	Ø Handle GN 798	⚖
GN 923.18-80-K6-R	80	6	26	17	13	7	16	26	43.5	16	150

GN 923.30

Description	d1	d2	d3	d4	b	h	l1	l2	l3	Ø Handle GN 798	⚖
GN 923.30-100-K8-R	100	8	28	22	14	9.5	17	30	58	18	200

